

**P/N : CL-P0187**

Application for: Intel LGA775 1U up to 3.8GHz



SPECIFICATIONS	
Compatibility	Intel LGA775 1U up to 3.8GHz
Dimension	(L)90.0 x (W)90.0 x (H)13.5 mm
Fan Dimension	ψ70x10 mm
Heat Sink Material	All Copper Base & Copper Fins
Rated Voltage	12 V
Operating Voltage Range	5.0~13.2 V
Rated Current	0.45 A (Max.)
Rated Speed	4800 rpm ± 10%
Air Flow	28.7 CFM
Static Pressure	3.34 mmH <sub>2</sub> O
Noise Level	40.3 dBA
Speed Controlled Type	N/A
Connector	3 Pin
Bearing	1 Ball
Life Expectancy	40,000 Hrs
Weight	427g



Top View



Bottom View



Side View



Back plate

## FEATURES:

- All copper fins and copper base Skived Technology.
- Spring screw mounting method ensure safe installation when shipping.
- High density copper thin fin: more surface area gives good heat dissipation.

## DIMENSION

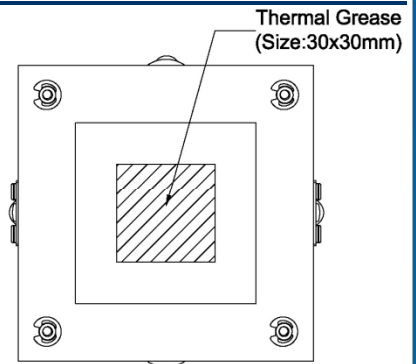
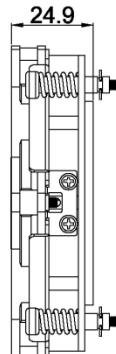
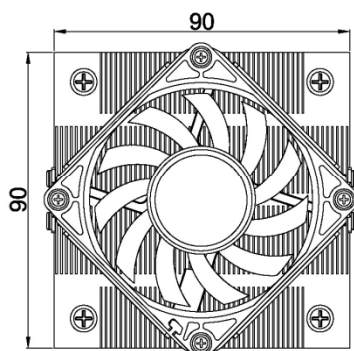

Unit: mm